

SWL	KG	250	500	1000	2000	3200	5000	6300
2 hoisting speed	m/min	8/2	4/1	4/1	4/1	4/1	3.2/0.75	3.2/0.75
Chain falls		1	2	2	2	2	2	2
Type		ST 0502	ST 0502	ST 1005	ST 2010	ST 3016	ST 5025	ST 6032
Output	kW	0.4/0.1	0.4/0.1	0.8/0.2	1.5/0.37	2.3/0.57	3.0/0.76	3.8/0.9
Duty cycle	% ED	50	50	60	60	60	60	50
<b>Dimensions</b>								
Chain hoist with hook suspension	A1	367	428	432	547	575	697	697
	A2	238	238	402	496	496	522	522
	A3	385	385	514	590	677	664	664
	A4	281	281	352	398	393	466	466
	A7	145	145	135	181	181	206	206
	A8	153	153	133	158	158	154	154
	A9	20	26	24	29	33	41	41
Chain hoist with trolley	B1	413	474	437	545	586	707	707
	B2	164	164	242	302	310	480	480
	B3	425	425	519	589	689	672	672
	B4	/	/	/	330	338	480	480
	B5	62	62	96	102	113	149	149
	B6	/	/	/	289	341*	403*	403*
	B7	42...180	42...180	58...300	66...300	66...300	82...300	82...300
<b>Weights</b>								
With hook suspension		16	18	41	75	82	136	150
With trolley		24	26	53	110	130	201	215

\* The travel motor is mounted on the opposite side

Standard Chain Hoist with Hook

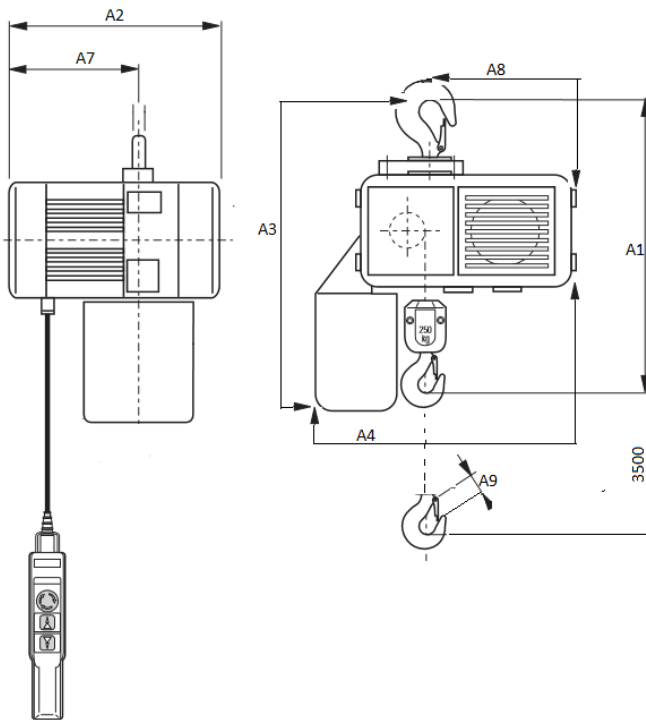

Hoist with Trolley

